

# Fiddle Club of the World Tunes in ABC notation for Make Music Chicago 2015

Click this link for downloadable recordings:

<http://drdosido.net/fiddleclub/tunes-for-make-music-chicago-2015/>

ABC notation is a useful tune developed for sharing tunes via email and the internet. It provides the note names in sequence, with other markings that provide information about rhythm and meter. It can provide an easy way to figure out what the notes are in a particular phrase or section. Used in conjunction with recordings, you don't have to pay much attention to the rhythm and meter markings (numbers and symbols). Here is a chart of the ABC notation note names as they pertain to the fiddle fingerboard.

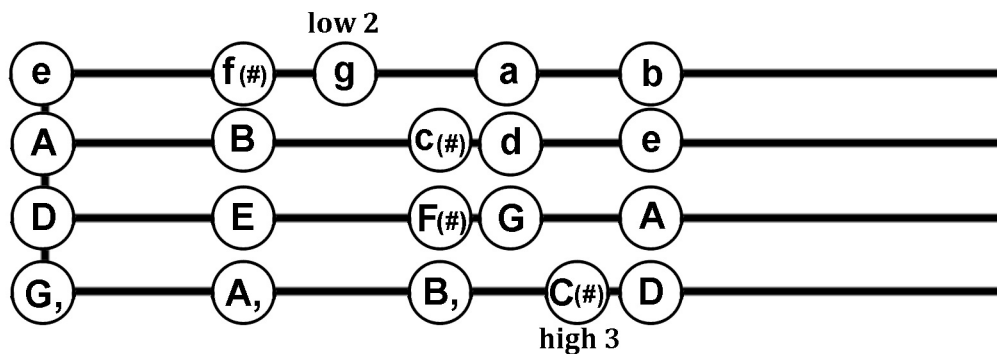

To learn more about how to use ABC notation, go to these websites:

<http://abcnotation.com/> and <http://trillian.mit.edu/~jc/doc/doc/ABCprimer.html>

Or check out the short tutorial found on the Old Town School's Fiddle Tune Archive.

<http://www.oldtownschool.org/fiddle/fun/abcnotationforfiddletunes9378.pdf>

A very handy internet tool is to copy one of the ABC blocks found below (starting with the X:) and past it into this website: <http://www.mandolintab.net/abconverter.php>.

Click submit, and the ABCs are turned into standard music notation. Then click the MIDI button, and your web browser should play the tune (as long as your settings for the .mid file type are for a player).

Click this link for a tunebook in standard notation:

<http://drdosido.net/fiddleclub/wp-content/uploads/2015/05/Make-Music-Chicago-Tune-book.pdf>

X:1

T:Big Betty

T:Little Betty Brown

M:C|

L:1/8

S:Gail Heil (more or less)

K:D

FE | D2F2 A3A | BAdB A2FG | A2d2 BAF2 | E3F E2FE |  
D2F2 A3A | BAdB A2FG | A2d2 fde2 | d3e d2 ::  
de | fefà fede | fgfe d2de | feaf edB2 | A3B A2FE |  
D2F2 A3A | BAdB A2FG | A2d2 fde2 | d3e d2 ;|

X:2

T:Blackthorn Stick

M:6/8

L:1/8

N:First tune in medley with Connaughtman's Ramblers.

K:G

d | gfg ege | dBG AGE | DGG FGA | BGB A2d |  
gfg age | dBG AGE | DGG FGA | BGG G2 ::  
d | edd gdd | edd gdd | edd gfe | dcB A2d |  
gfg age | dBG AGE | DGG FGA | BGG G2 ;|

X:23

T:Connaughtman's Rambles

M:6/8

L:1/8

N:Second tune in Medley with Blackthorn Stick.

K:D

A/G/ | FAA dAA | BAA dAG | FAA dfe | dBB B2A/G/ |  
FAA dAA | BAB def | gfe dfe | dBB B2 ::  
e | fbb faa | fef deg | fbb faa | fed e2g |  
fbb faa | fef def | gfe dfe | dBB B2 ;|

X:3

T:Brud Polkka efter Edward Öst

M:C|

L:1/8

S:Arto Järvelä from Edward Öst

K:A

c2A2 AcAc | {fg} f2e2 c4 | c2A2 AcAc | d2B2 B4 |  
{cd} c2A2 AcAc | f2e2 c4 | c2A2 c3B | A2G2 F4 ::  
{efg} a3g f2c2 | ef2e c2A2 | F2G2 A2c2 | BAGA F2E2 |  
a3g f2c2 | ef2e c2A2 | F2G2 A2c2 | BAGA F4 ;|

X:4

T:Celeya Polka

M:C|

L:1/8

S:Gu-Achi Fiddlers

K:G

A | B2d2 B3A | B2d2 c3A | c2d2 c2d2 |1 c2d2 B3 :|2 c2d2 B3 |:  
ggg | g2e3 gfe | g2d3 BcB | d2A3 cBc| d4- dggg |  
g2e3 gfe | g2d3 BcB | d2A3 cBA |1 B4- B :|2 B6 z ||

X:4

T:Celeya Polka (harmony)

M:C|

L:1/8

S:Gu-Achi Fiddlers

K:G

D | G2B2 G3D | G2B2 A3D | A2B2 A2B2 |1 A2B2 G3 :|2 A2B2 G3 |:  
eee | e2c3 edc | B2G3 GAG | F2D3 AGA| B4- Beee |  
e2c3 edc | B2G3 GAG | F2D3 AGF |1 G4- G :|2 G6 z ||

X:5

T:Daylight in the Morning

M:C|

L:1/8

S:Jim Lansford from Uncle Bunt Williams

K:G

GA | B2d2 d3d | e2d2 d2GA | B2d2 dedB | A2G2 G2GA |  
B2d2 d2Bd | e2d2 d2GA | B2d2 dedB | A2G2 G2 ::  
GB | A2GB {AB} A2GB | A2G2 E2GB | {AB} A2GB A2GE | D2E2 G2GB |  
A2GB {AB} A2GB | A2G2 E3G | D2c2 cdcA | D2E2 G2 :|

X:6

T:Devil in the Hay Stack

M:C|

L:1/8

S:Garry Harrison from Pappy Taylor

K:Amix

e2ag e2d2 | cdef gfed | e2ag e2d2 | cdef g4 |  
agag e2d2 | cdef gfed | e2ag e2d2 | cABA A4 ::  
A2c2 A2c2 | Acef gfed | BG3 [G4B4] | BAGB AGEG |  
A2c2 A2c2 | Acef g4 | a2ag e2d2 | cABA A4: |

X:7

T:Golden Slippers

M:C|

L:1/8

K:G

GA| B2Bc BAGA | B2Bc BAGA | B2B2 c2Bc | B2A2 A2FG |  
A2AB AGFG | A2AB AGFG | A2A2 B2AB | A2G2 G2 :|  
E2 | D6 G2 | B2A2 G2F2 | E6 G2 | c2B2 A2G2 |  
F3E F2G2 | A3B A2F2 | G3F G2A2 | B3c BAGE |  
D6 G2 | B2A2 G2F2 | E6 G2 | c2B2 A2G2 |  
F3E F2G2 | A4 c4 | A2c2 B2A2 | G3A G2 |:  
Bc | d2Bc d2B2 | A/B/AG2 G2B2 | d3B d2g2 | f3g f2AB |  
c3d c2B2 | ABAG F2FE | D2D2 EDEF | G3A G2 :|

X:7

T:Golden Slippers (harmony)

M:C|

L:1/8

K:G

Bc| "harmony" d2de dcBc | d2de dcBc | d2d2 e2de | d2c2 c2AB |  
c2cd cBAB | c2cd cBAB | c2c2 d2cd | c2B2 B2 :|  
z2 | G6 B2 | d2c2 B2A2 | G6 c2 | e2d2 c2B2 |  
A3G A2B2 | c3d c2A2 | B3A B2c2 | d3e dcBA |  
G6 B2 | d2c2 B2A2 | G6 c2 | e2d2 c2B2 |  
A3G A2B2 | c4 e4 | c2e2 d2c2 | B3c B2 ||

X:8

T:Hast Schottis

M:C|

L:1/8

S:Mary Allsopp & Chicago Spelmanslag

K:G

D2-|D2BA G2G2-| GDGB d2d2 | edcB c2A2- | AdcB B2G2 |  
D2BA G2G2-| GDGB d2g2 | geec cAFA | G2B2 G2 ::  
Bd|e2ce g2fe | dBGB d2d2 | D2FA c2c2 | BAGB d2d2 |  
e2ce g2fe | dBGB d2g2 | geec cAFA | G2B2 G2 :|

X:9

T:Missouri Waltz

M:3/4

L:1/8

S:Lotus Dickey

K:G

B6 | g6 | e3g ed | B6 | c3B c2 | A3B c2 | B3c BG | E6 |  
B6 | g6 | e3g ed | B6 | c3B cB | A4 BA | G3A Bd | e2^d2=d2 |:  
B3c (3BAG | A3^G Ac | B3c BA | G6 | B3c (3BAG | A3^G Ac |  
B3c BA | G2F2 =F2 | E2 G3A | G2 E3E | D2 G3A | G2D2 D2  
|1 E3F E2 | E2G2 E2 | F3=F ^F2 | d2^c2 =c2 :|2 E6 | B4 BA | G6- | G2 z4 ||

X:10

T:Polonæse Svøbsk

M:3/2

L:1/8

S:Jensen & Bugge

K:D

"D" A2Bc d3c d4 | "A" ABcd e3d e4 | "Bm" f3e d2c2 "Em" B4 | "G" efed "E7" c2B2 "A" A4 |

"D" A2Bc d3c d4 | "A" ABcd e3d e4 | "Bm" f2a2 "G" g2f2 e2d2 |\

M:2/2

"A" c2d2 e4 | d3c "D" d4 ::

M:3/2

"Bm" f3e d2c2 "G" B4 | "Em" efed c2B2 "A" A4 | "Bm" f3e d2c2 "Em" B4 | "G" efed "E7" c2B2

"A" A4 |

"D" A2Bc d3c d4 | "A" ABcd e3d e4 | "Bm" f2a2 "G" g2f2 e2d2 |\

M:2/2

"A" c2d2 e4 | d3c "D" d4 :|

X:10

T:Polonæse Svøbsk (harmony)

M:3/2

L:1/8

S:Jensen & Bugge

K:D

"D" D3E F3E F4 | "A" FGAB c3B c4 | "Bm" d3c B2A2 "Em" G4 | "G" G3F "E7" E2D2 "A" C4 |

"D" D3E F3E F4 | "A" FGAB c3B c4 | "Bm" d2f2 "G" e2d2 c2B2 |\

M:2/2

"A" A2B2 c4 | A3G "D" F4 ::

M:3/2

"Bm" d3c B2A2 "G" G4 | "Em" GAGF E2D2 "A" C4 | "Bm" d3c B2A2 "Em" G4 | "G" G4 "E7"

B,2D2 "A" E4 |

"D" D3E F3E F4 | "A" FGAB c3B c4 | "Bm" d2f2 "G" e2d2 c2B2 |\

M:2/2

"A" A2B2 c4 | A3G "D" F4 :|

X:11

T:Purple Lillies Polka

M:C|

L:1/4

S:Gu'Achi Fiddlers

K:D

F/G/A | "high voice" BB AA | F2 F/G/A | BB A^G | G2 G>A |

BB A^G | G2 A>B | cB AG |1 F2 :|2 F4- | Fd dc |

e2 c2- | cc cB | d2 A2- | Ad dc |

e2 c2- | cc cB | d2 A2- | AF GA |

B2 d2- | dd dc | e2 c2- | c2 c>d |

ec dB | cA BG | AF G/F/E | F4- | F2 ||

X:11

T:Purple Lillies Polka (low)

M:C|

L:1/4

S:Gu'Achi Fiddlers

K:D

D/E/F | "low voice" GG FF | D2 D/E/F | GG F^E | E2 E>F |  
GG F^E | E2 F>G | AG FE |1 D2 :|2 D4- | DB BA |  
c2 A2- | AA AG | B2 F2- | FB BA |  
c2 A2- | AA AG | B2 F2- | FD EF |  
G2 B2- | BB BA | c2 A2- | A2 A>B |  
cA BG | AF GE | FD E/D/C | D4- | D2 ||

X:12

T:Rusty Gulley

M:3/2

L:1/8

S:Folkestra

K:G

GABc d2 G2 B2 G2 | F2 A4 c2 B2 A2 | GABc d2 G2 B2 G2 | D2 G4 B2 A2 G2 ::  
g4 f4 ef g2 | f2 d4 f2 e2 d2 | c4 B4 AB c2 | B2 G4 B2 A2 G2 ;|

X:13

T:Scotis

M:C|

L:1/8

S:Compagnia Sonadùr Di Ponte Caffaro

K:D

DF | A2DF B2DF | A2d2 d2fg | a2e2 agfe | g2f2 f2DF |  
A2DF B2DF | A2d2 d2fg | a2e2 agfe | d2f2 d2 ::

K:A

(3efg | a2a2 g3g | a2a2 a2gf | e2ef edcB | d2c2 c3g |  
a2a2 g3g | a2a2 a2gf | e2ef edcB | A2c2 A2 ;|

K:G

zd | B3d B3d | g2g2 g2fe | d2de dcBA | c2B2 B3d |  
B3d B3d | g2g2 g2fe | d2de dcBA | G2B2 G2 ;|

X:13

T:Scotis (harmony)

M:C|

L:1/8

S:Compagnia Sonadùr Di Ponte Caffaro

K:D

D2 | F2DF G2D2 | F2A2 A2B2 | c2A2 cBAG | B2A2 A2D2 |  
F2DF G2D2 | F2A2 A2B2 | c2A2 cBAG | F2A2 F2 ::

K:A

z2 | c2c2 B3B | c2c2 c2BA | G2GA GFED | F2E2 E3z |  
c2c2 B3B | c2c2 c2BA | G2GA GFED | C2E2 C2 ;

K:G

zB | G3B G3B | B2B2 B2AG | F2FG FEDC | E2D2 D3B |  
G3B G3B | B2B2 B2AG | F2FG FEDC | B,2D2 B,2 ;

X:14

T:Snouts and Ears of America

M:C|

L:1/8

S:Chirps Smith from Sarah Armstrong

K:D

(3ABc | d2D2 D2D2 | F2A2 d2ed | c2A2 ABcd | e2A2 A2Bc |  
dcBA G2F2 | E2D2 A3G | F2D2 EDEG | F2D2 D2 ::  
AG | F2D2 D3E | FA3 A2BA | G2E2 E4 | Ad3 d2AG |  
F2D2 D3E | FA3 A2BA | G2E2 A3G | F2D2 D2 ;

X:15

T:Storm

M:C|

L:1/8

S:Jensen & Bugge from Dwight Lamb

K:G

DD | D2E2 D2C2 | B,6 BB | B2c2 B2A2 | G6 Bd |  
c2B2 A2G2 | B2D2 G2A2 | B4 A4 | G6 ::  
GA | B2G2 B2G2 | A2DD D2AB | c2A2 c2A2 | B2G2 B2d2 |  
e2d2 e2f2 | g3e d2c2 | B4 A4 | G6 ;

X:16

T:Sullivan's Polka

M:C|

L:1/8

N:First tune in a medley with Britches Full of Stitches.

S:Kevin Burke

K:A

z| a4a3f| e2c2 a4 | c2e2 a3f| e2c2 B2A2 |  
a4a3f| e2c2 a4 | c2e2 B3c | B2A2 A3 ::  
B | c2e2 e2c2 | d2f2 f3d | c2e2 e2AB | c2B2 B2AB |  
c2e2 e2c2 | d2f2 f2d2 | c2e2 B3c | B2A2 A3 ;

X:16

T:Britches Full of Stitches

M:C|

L:1/8

N:Second tune in a medley with Sullivan's Polka.

S:Kevin Burke

K:A

A3B c2A2 | B2A2 c2A2 | A3B c2A2 | B2A2 F4 |  
A3B c2A2 | B2A2 c2e2 | A3B A2F2 | F2E2 E4 ::  
e3fe2c2 | B2A2 B2c2 | e3fe2c2 | B2A2 F4 |  
e3fe2c2 | B2A2 B2c2 | A3B A2F2 | F2E2 E4 ;|

X:17

T:Spooof Polonessa #8

M:3/4

L:1/16

O:

S:Arto & Antti Järvelä

K:D

A2 | f2ef e2c2 d2e2 | {e} f2ef e6A2 | f2ef e2c2 d2e2 | [{fg} f2ec d6 ::  
A2 | f2ef g2fg a4 | d2g2 gfd e4 | f2ef g2fg a3g | f2e2 d6 ;|

X:17

T:Polonessa #1

M:3/4

L:1/8

S:Arto & Antti Järvelä

K:D

cd | ef ec cd | efe2- ef/g/ | ga fe dc | cdd2 cd |  
ef ec cd | efe2- ef/g/ | ga fe dc | cdd2 ::  
e/f/g | fga2 d2 | ba ag ge | efa2 d2 | ba ag ge |  
(3fed c2d2 | efe2- ef/g/ | ga fe dc | cd d2 ;|

X:18

T:She Oughta Been a Lady

M:C|

L:1/8

S:Vesta Johnson

K:D

FG | A2AB A3A | BABd e2d2 | faaf e2fe | dcdA BdA2 |  
FA2B A2AA | BABd e2d2 | faaf efe2 | d3e d2 ::  
fg | a2af a2af | gfga b2a2 | faaf e2fe | dcdA BdA2 |  
FA2B A2AA | BABd e2d2 | faaf efe2 | d3e d2 ;|



X:19

T:Ten Cents

M:C|

L:1/8

S:Chirps Smith

K:G

D2Bc BAGF | E2c4 cB | A2B^c d2cd | e2d2 dedB |  
D2Bc BAGF | E2c4 cB | A2Bc dcBA | GBAF G2G2 ::  
G2g2 ggeg | f2d4 AB | d2fa b3f | a2g2 gag2 |  
G2g2 ggeg | f2d4 d2 | Bcde dcBc | dcAF G1G1:|

X:20

T:Vengerka

M:C|

L:1/8

S:Indrek Kalda & Tiits Kikus

K:G

GFGA BABc | d^cde d4 | g2BB d2Bc | BAA^G A4 |  
D^CDE FEFG | A^GAB cedB | BdBG AcFA | AGGF G4 ::  
g3fe3c | e4 e4 | c8 | a3g f2e2 | dcBc d4 |  
D^CDE FEFG | A^GAB cedB | BdBG AcFA | AGGF G:|

X:21

T:Vidar's Vals

M:3/4

L:1/8

S:Vidar Skrede

K:G

GE | D2BD Bd | D2BD Bd | cB Ac eg | gf ge d2 |  
D2BD Bd | D2BD Bd | cB AD FF | G4 ::  
GA | B2 ba g2 | f6 | g4 a2 | c4 cB |  
A2 AG AB | c2 cA ce | g2 ge c2 | d3c BA |  
B2 ba g2 | f6 | g4 a2 | c4 cB |  
A2 AG AB | c2 cD FF | G2 AG AB | G4:|

X:22

T:Walk Old Shoe, Heel Come a-Druggin'

M:C|

L:1/8

S:Garry Harrison from Pauline McGinnis

K:D

D3D F2A2 | d2d2 BAFG | A2AB AFDE | F2E2 E4 |  
D3D F2A2 | d2d2 BAFG | A2AB AFDE | F2E2 D4 ::  
D2fe fed2 | edBA BAFG | A2AB AFDE | F2E2 E4 |  
D2fe fed2 | edBA BAFG | A2AB AFDE | F2E2 D4:|

X:24

T:El Viento

M:4/4

L:1/8

S:Trio Ollín

K:G

BA | B2B2 B2BA | B2B2 B2BA | B2B2 B2Bc | d2d2 d2ef|g2g2 g2fè |  
d2d2 d2ed | c2c2 c2dc | B2B2 B2cB | A2A2 A2BA |1 G2G2 G2:|2 G2G2 G2 |:  
f2 | e2d2 c2B2 | A4 GABG | A4 GABG | A6 g2 |  
f2e2 d2c2 | B4 ABcA | B4 ABcA |1 B4 B2 :|2 B4 B4 B2Bd |:  
e4 e4 | e2ef g2fè | d4 B4 | e4 e4 | e2ef g2fè |  
d2B2 d2g2 | f2d2 f2a2 |1 g4 g4:|2 g4 g2||  
"Coda"b2b4 | g2g4 | d2d4 | B2G2B2 | g6 ||

X:24

T:El Viento (harmony)

M:4/4

L:1/8

S:Trio Ollín

K:G

GF | G2G2 G2GF | G2G2 G2GF | G2G2 G2GA | B2B2 B2cd | e2e2 e2dc |  
B2B2 B2cB | A2A2 A2BA | G2G2 G2AG | F2F2 F2DC |1 B,2B,2 B,2:|2 B,2B,2 B,2 |:  
d2 | c2B2 A2G2 | F4 EFGÉ | F4 EFGÉ | F6 e2 |  
d2c2 B2A2 | G4 FGAF | G4 FGAF |1 G4 G2 :|2 G4 G4 G2GB |:  
c4 c4 | c2cd e2dc | B4 G4 | c4 c4 | c2cd e2dc |  
B2G2 B2d2 | c2F2 A2c2 |1 B4 B4:|2 B4 B2||  
"Coda"g2g4 | d2d4 | B2B4 | G2D2G2 | B6 ||